

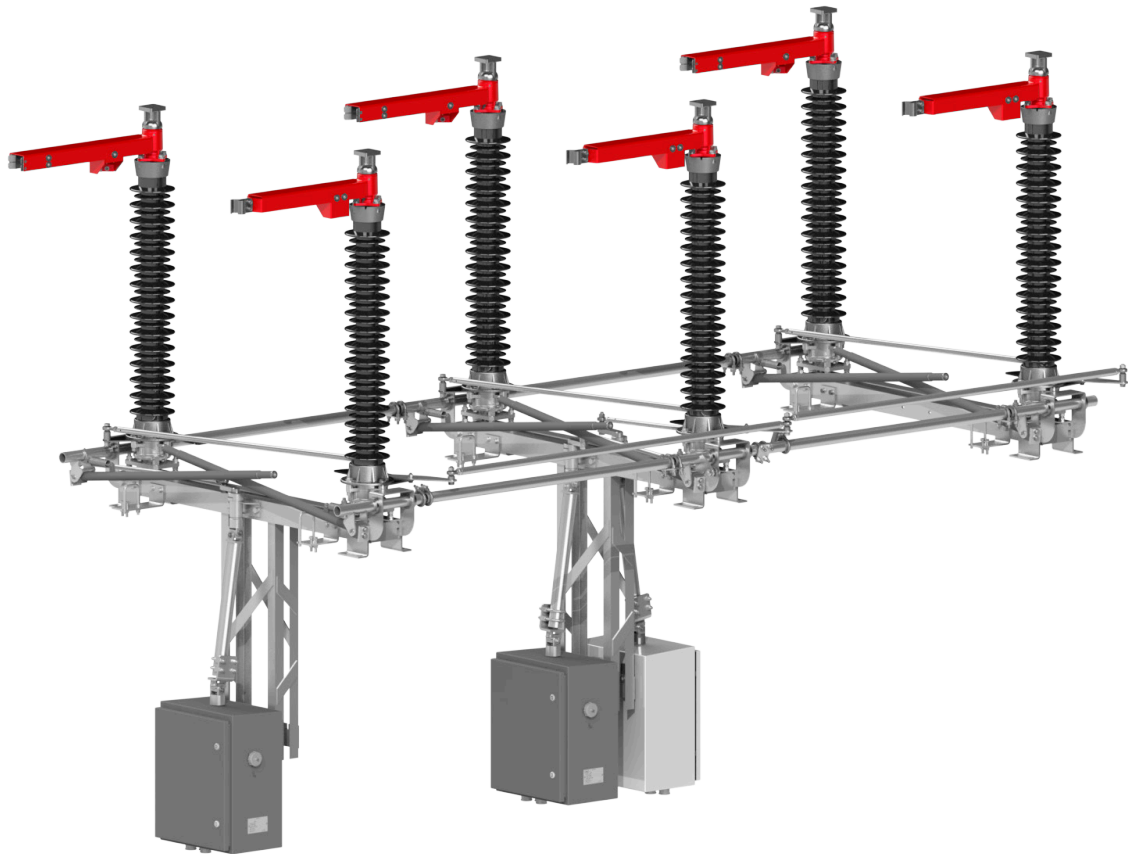

Zakład Wytwórczy Aparatów Elektrycznych Sp. z o.o.
Installation and service manual



ONIII

Outdoor disconnector 40kA

Manual No DTR.01.11.02.EN

We connect
with ENERGY

.....○ WARNING

During the operation of electrical equipment, certain parts of these devices are normally under dangerous voltage, and mechanical parts, also remotely controlled, can move quickly.

Failure to follow the warning instructions can result in serious personal injury or material damage.

Only suitably qualified personnel can work on or near the device. This personnel must know exactly all safety rules and rules for maintaining the device in accordance with these instructions.

The problem-free and safe operation of this device requires proper transport, proper storage, construction and assembly as well as careful service and maintenance.

Table of Contents

1. TRANSPORT	4
1.1 Unpacking and inspection.	4
1.2. Storage and transport.	4
2. DESCRIPTION	6
2.1. Construction and principle of operation.	6
2.2. Climatic conditions.	6
2.3. Nameplate	7
2.4. Basic technical parameters.	7
3. INSTALLATION AND ADJUSTMENT	8
3.1. Preparing contact surfaces	8
3.2. Poles adjustment	8
3.3. Disassembly of the transport lock	9
3.4. Operating mechanism assembly.	10
3.5. Pole coupling and adjustment.	10
3.6. Earthing switches coupling	13
3.7. Earthing switches operating regulation	14
3.8. Grounding of the base frames.	15
4. OPERATING MANUAL	15
4.1. Notes about connecting activities	15
5. INSPECTIONS AND MAINTENANCE	16
5.1. Visual inspections.	16
5.2. Periodical check-ups	16
5.3. Spare parts and recommended service materials	17
6. UTILIZATION	18

1. TRANSPORT

1.1 Unpacking and inspection

Immediately after receiving the disconnecter it should be checked the delivery compliance with the shipping specification. Then should be checked whether the disconnecter has not been mechanically damaged during transport and the data on the nameplate match the order.

1.2. Storage and transport

Disconnecter poles are transported in assembled condition. During the unloading and assembly process, the disconnecter poles should be lifted using transport belts, placed in the manner shown in the following graphic.

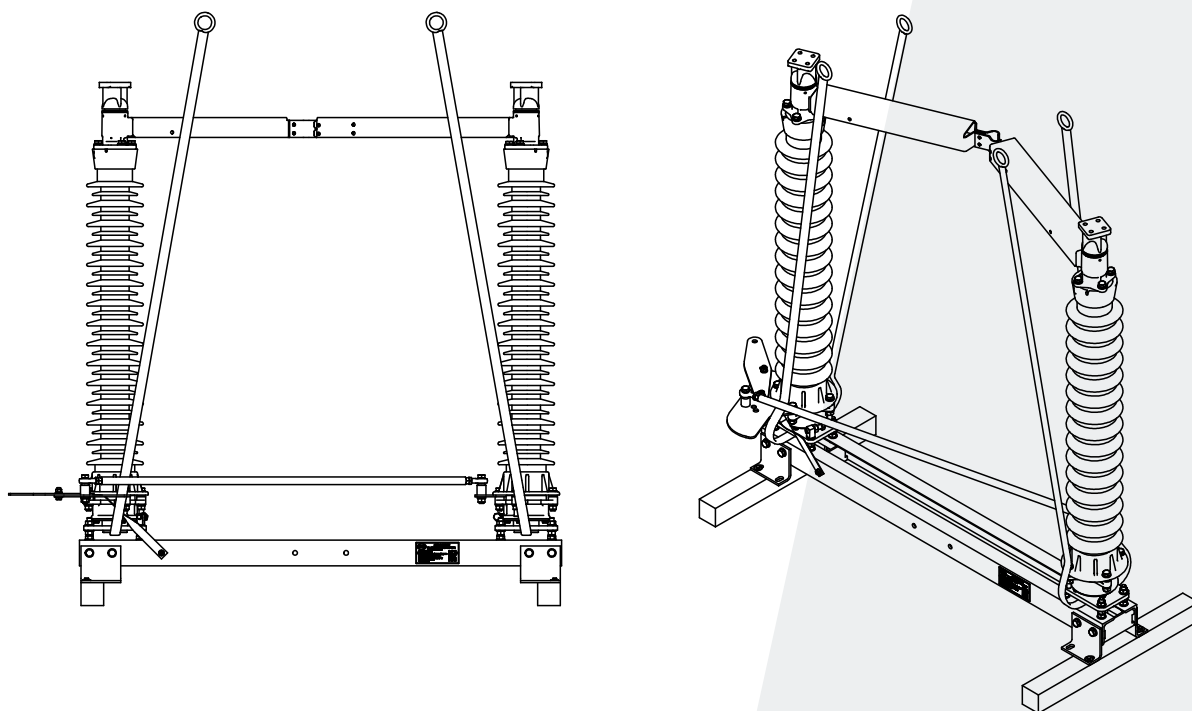

During transport, disconnecter poles are placed on wooden beams, which should be removed immediately before placing the pole on the supporting structure, unscrewing the four screws with a wrench size 13.

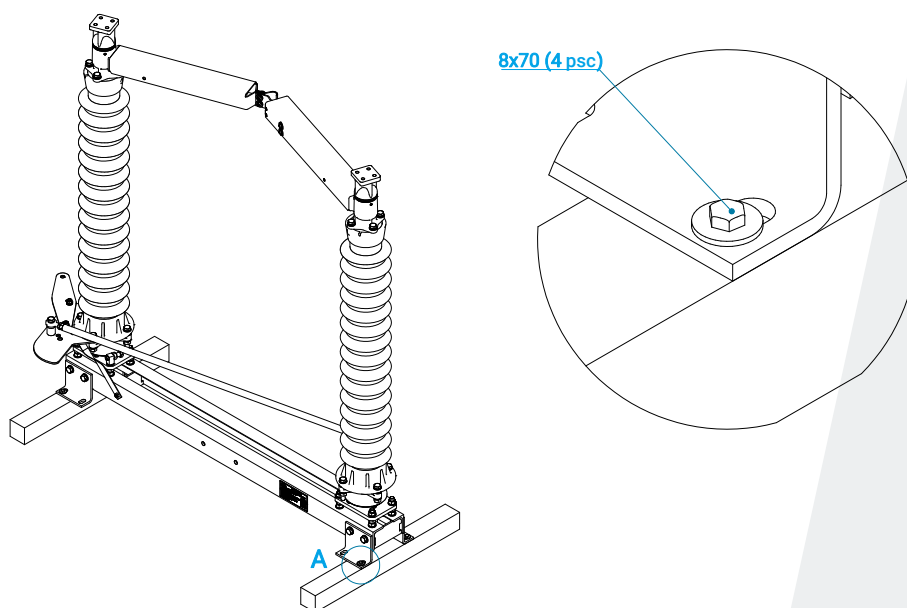

During transport poles must be secured against tipping over and the central contact should be open. The disconnector can be transported by means of transport with open cargo area. On flat, hard surfaces it is allowed to move the disconnector's poles with a pallet truck in the manner shown below, with particular care to prevent the pole from tipping over.

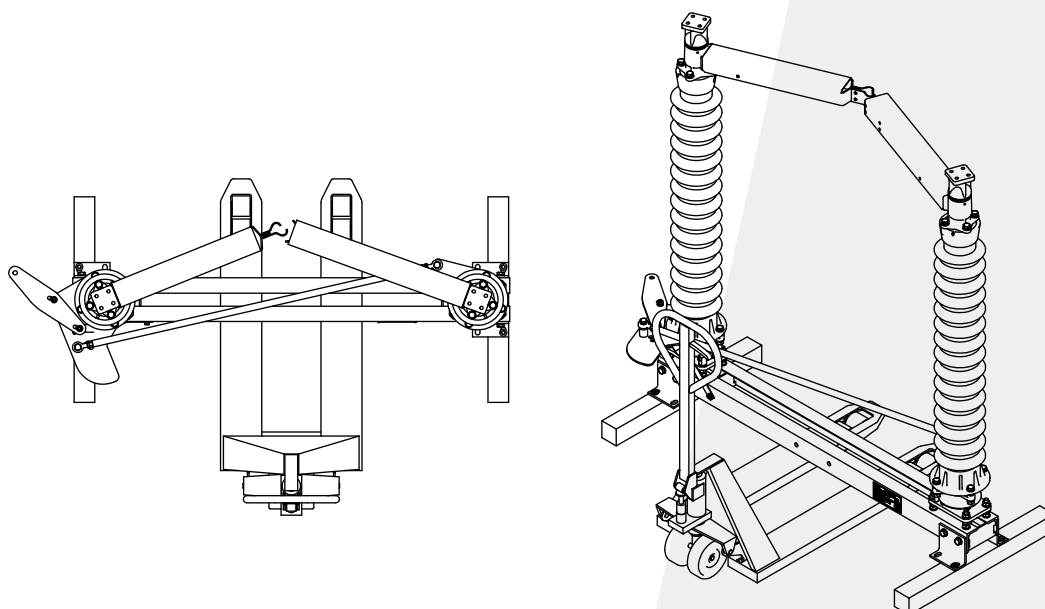

Disconnector poles can be stored in an open space but poles should be put so that the base does not stand directly on the ground.

2. DESCRIPTION

2.1. Construction and principle of operation

Outdoor disconnector type ONIII- ... is an insulating, two-column switch, with horizontal contacts movement. It is designed to work in networks with voltage corresponding to the rated voltage, at frequencies up to 60 Hz inclusive. The disconnector can be used as a single-pole switch with an individual operating mechanism or in three-pole set with one common operating mechanism. Disconnector poles can be set in parallel or in serial connection. Disconnector visual drawing in parallel configuration is shown below.

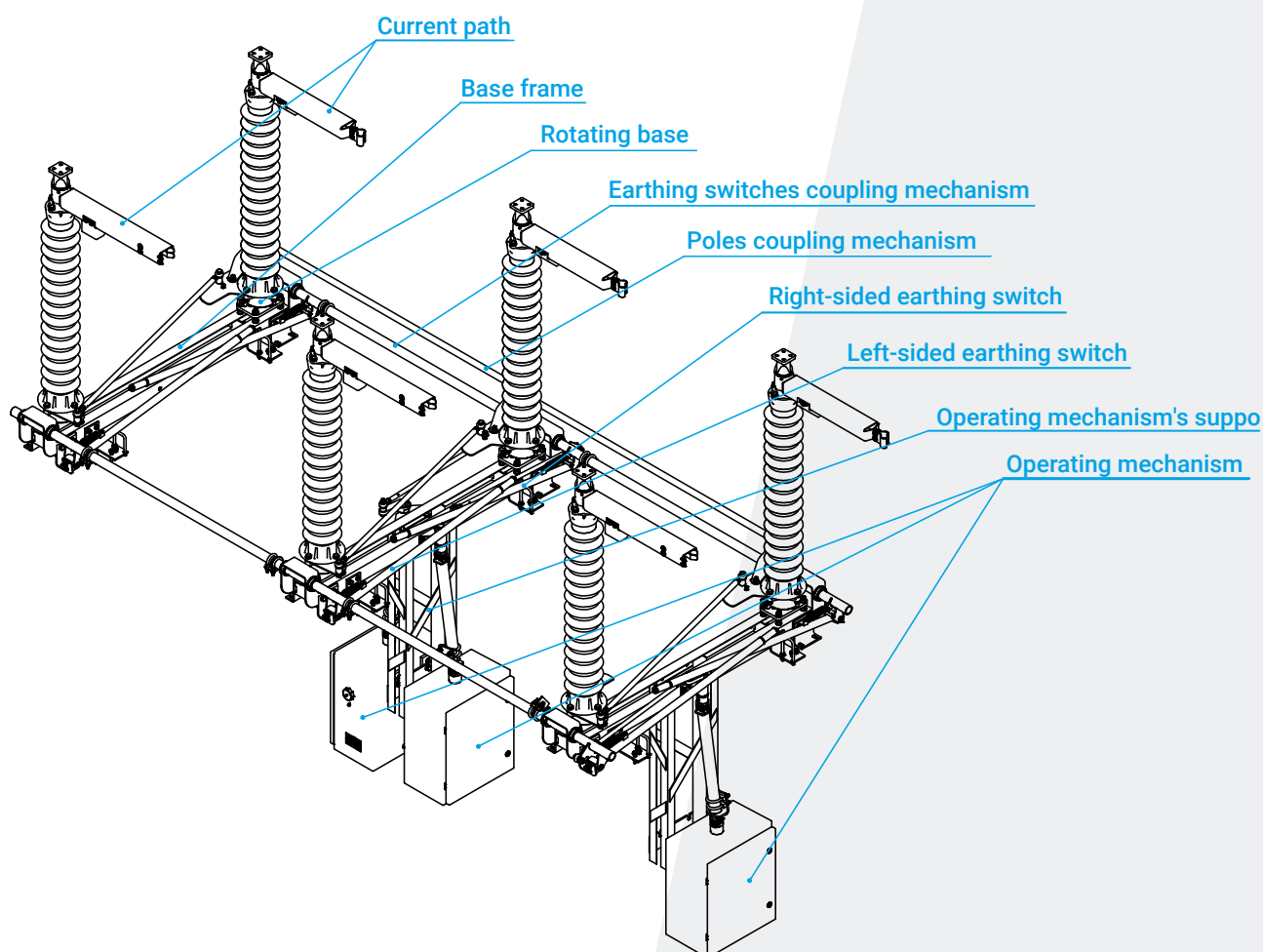

2.2. Climatic conditions

The disconnector is designed for outdoor operation, at ambient temperature from -50 to +40° C and relative humidity up to 100%.

2.3. Nameplate

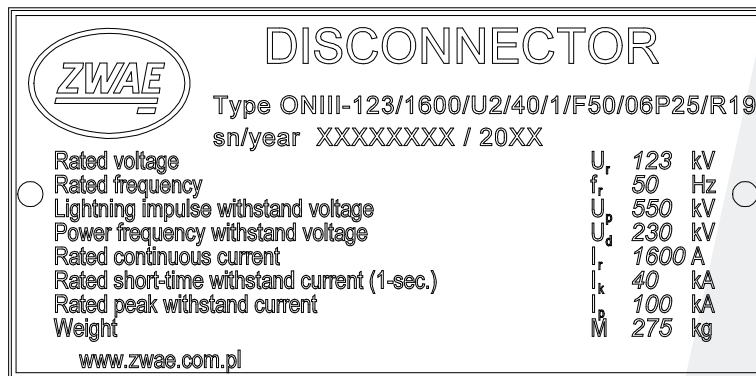

2.4. Basic technical parameters

No.	Parameter	Value	
1.	Rated operating voltage	72,5 [kV]	123 [kV]
2.	Rated current	1600 [A]	1600 [A]
3.	Peak current	100 [kA]	100 [kA]
4.	Short-circuit current, 1-sec.	40 [kA]	40 [kA]
5.	Short-circuit current, 3-sec.	31,5 [kA]	31,5 [kA]
6.	Test voltage (50 Hz) for insulation: - to earth and between phases, - between contacts of one pole.	140 [kV]	230 [kV]
		160 [kV]	265 [kV]
7.	Surge test voltage for insulation: - to earth and between phases, - between contacts of one pole.	325 [kV]	550 [kV]
		375 [kV]	630 [kV]
8.	Radio interference voltage	<1000 [µV]	<1000 [µV]
9.	Rated mechanical operating life:	2000 cycles	2000 cycles
10.	Dedicated operating mechanism: - motor, - manual.	NS080	NS080
		NR-5	NR-5

3. INSTALLATION AND ADJUSTMENT

The delivered disconnecter is completely regulated and ready to work. Assembly is reduced to:

- a) installation poles on a supporting structure,
- b) attaching supporting construction for the operating mechanisms,
- c) installation of operating mechanisms,
- d) poles coupling and regulation,
- e) earthing switches coupling,
- f) earthing switches regulation,
- g) grounding the base frame and operating mechanisms.

3.1. Preparing contact surfaces

Contacts resistance depends primarily on the quality and cleanliness of the contact surface. These surfaces should be very precisely prepared. The method of preparing aluminum and silver contacts surfaces is described below:

• aluminum – aluminum connection

Remove the oxide layer from the contact surface with a wire brush. After this treatment, the surface should be matt gray, devoid of shiny areas. Clearly remove shavings and aluminum dust from the surface, for example by lubricating with acid-free grease and then removing it. After this treatment, the surface should be greased with acid-free grease to protect it from oxidation of aluminum. The prepared surface should not be exposed to the atmosphere longer than the time needed to prepare the cooperating surface.

• copper – silver connection

The copper surfaces should be cleaned of oxides with a brass wire brush and then proceed as for the aluminum surface. Silver surfaces do not need to be cleaned with a brush, but they can be cleaned with a mild abrasive, for example steel wool. After cleaning, cover the surface with a thin layer of acid-free grease.

3.2. Poles adjustment

The disconnecter poles should be placed on the supporting structure, which has mounting holes in accordance with the drawing below.

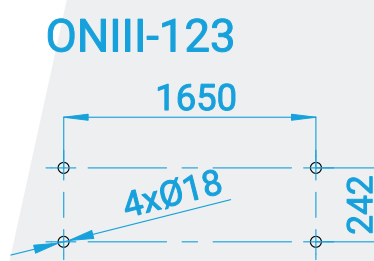
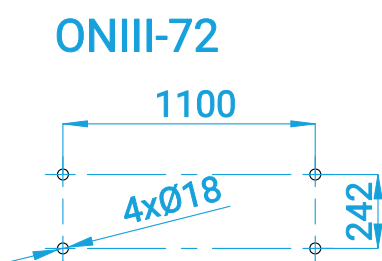

3.3. Disassembly of the transport lock

Remove the transport blockade from the poles attached to the supporting structure.

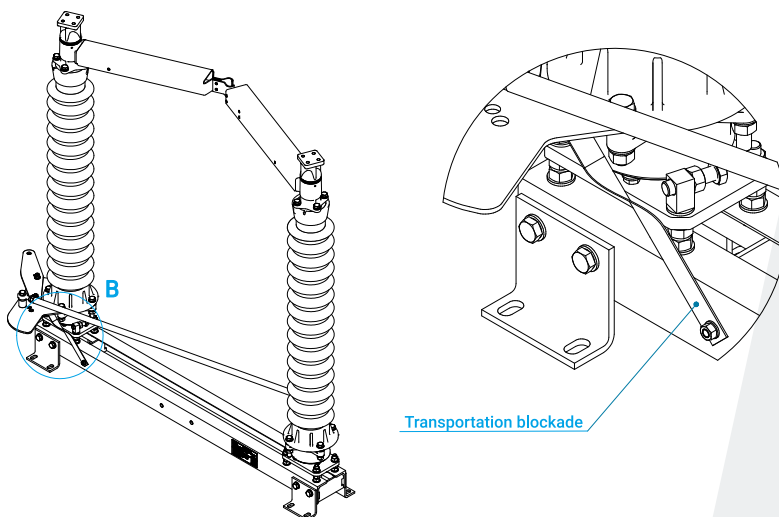

To remove the blockage, unscrew the M10 screw in the disconnecter base frame and the M12 screw in the drive lever has to be unscrewed. After removing the blockage, the M12 screw must be crewed back in the same place.

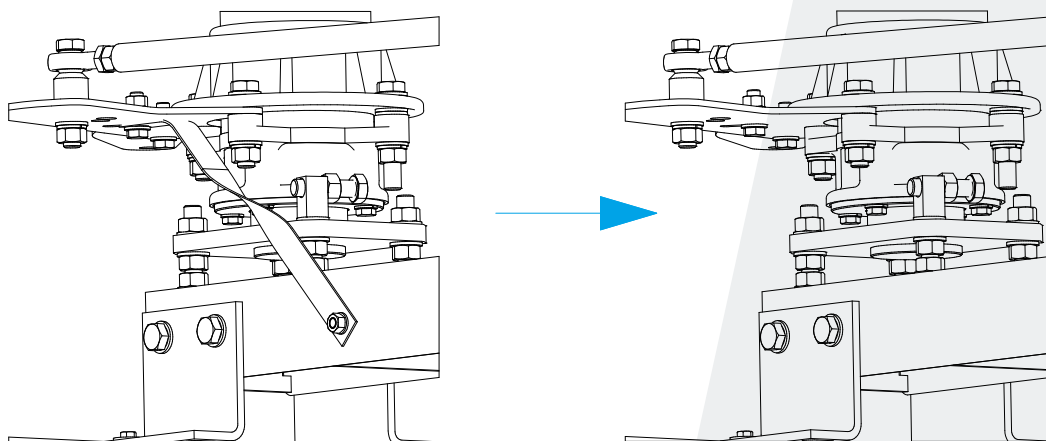

3.4. Operating mechanism assembly

The operating mechanism should be mounted on the supporting structure, under driving crank located in disconnector base. After the operating mechanism is assembled, the coupling shaft must be attached to connect the operating mechanism to the crank. The assembly method is shown in the figure below.

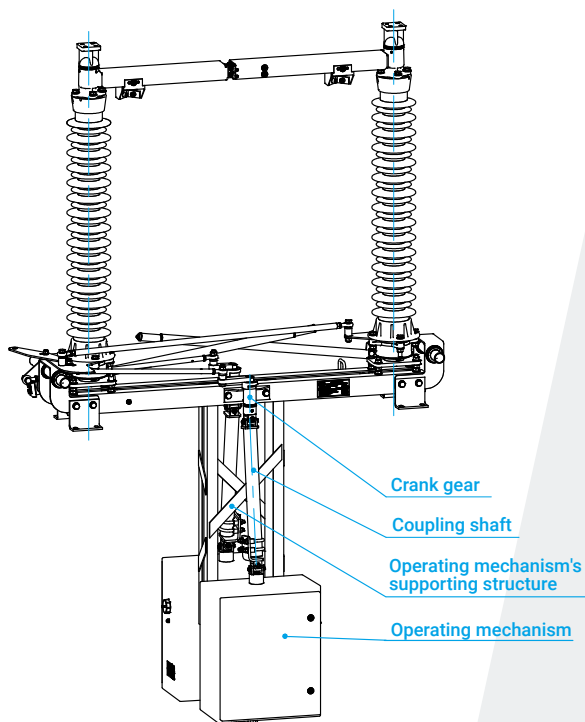

Tightening torque: M12 - 80 Nm, M16 - 100 Nm.

3.5. Pole coupling and adjustment

After setting the poles on the supporting structure, check the end positions of the current paths and, if necessary, correct the position of the bumpers and the lengths of the shafts of the disconnector kinematic system. After checking the correctness of operation of the poles the coupling rods can be assembled.

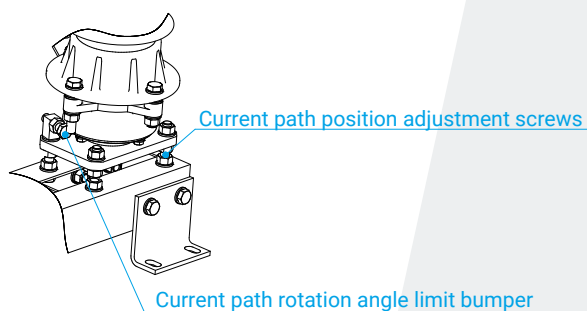

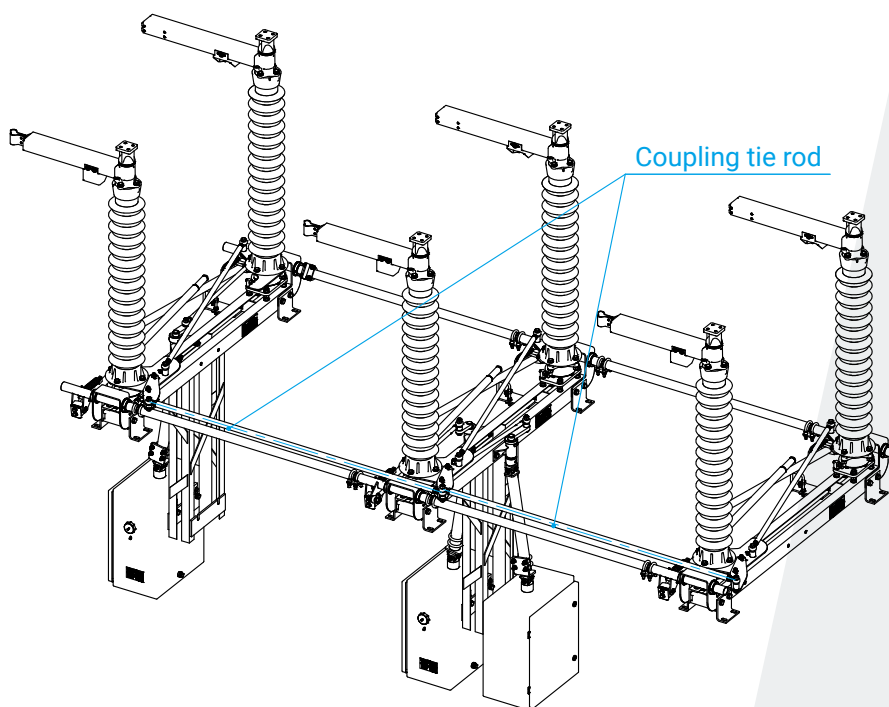

Tightening torque of M16 screws - 100 Nm.

Poles coupling regulation consists of such a setting of the length of the tie rod and coupling lever location adjustment so that the current paths at each pole reach the limit positions according to the following requirements.

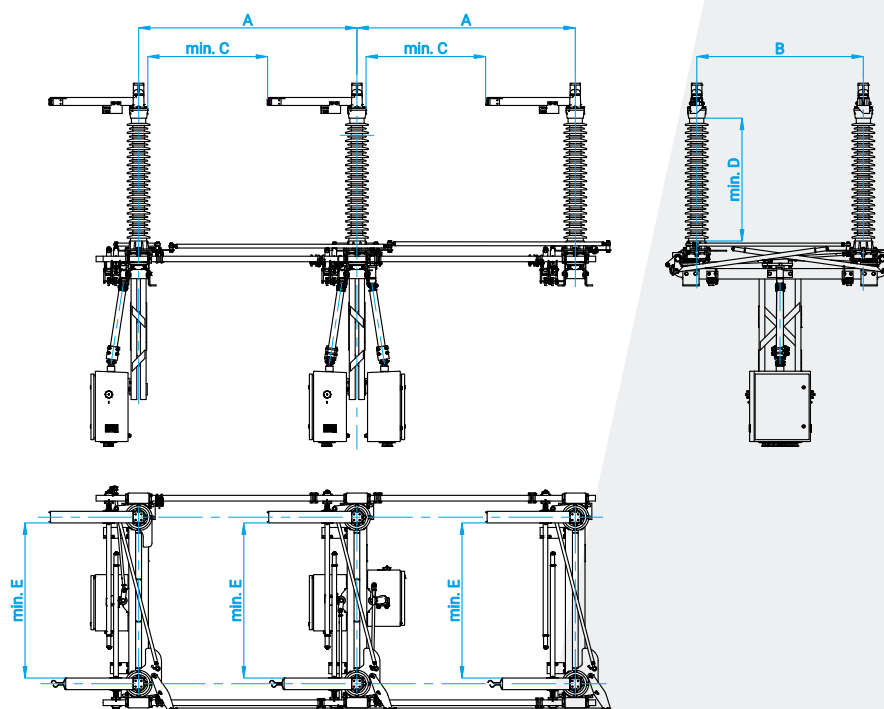

Regulation process should be performed in following way:

- a) Initially coupling tie rods should be installed in such a way that one pole would not be connected (tie rod ending hang on a line below coupling lever);
- b) Coupling tie rod should be extended or shortened in such a way that current path in driving pole would be achieve require limit positions. If tie rod length change forecloses achievement of the limit positions driving lever position should be changed on driving pole. The next figure presents the behavior of the disconnecter's poles when changing the position of the dive lever while maintaining the same length of tie rod. After changing the position of the lever it is necessary to correct the of the tie rod and check limit positions of the current path.
- c) After finishing one pole coupling regulation it is permitted to tighten up tie rod to the last pole and repeat steps from subpoint b.

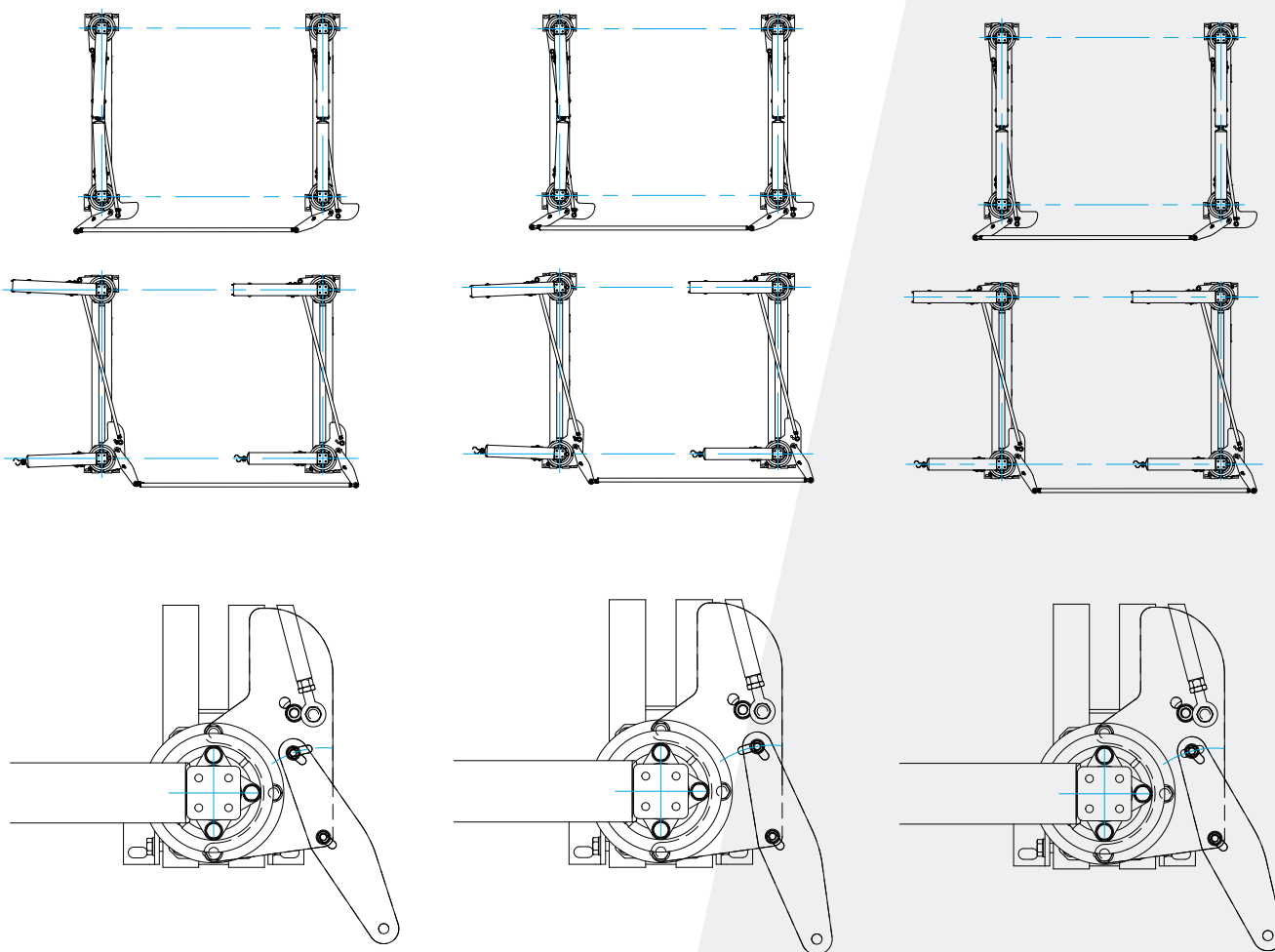

Regulation lever
– left position.

Regulation lever
– right position.

Regulation lever
– neutral position.

3.6. Earthing switches coupling

Earthing switches have to be coupled using coupling shafts, which length is presented in the table below.

Type	Application	
	Coupling shaft – left earthing switch	Coupling shaft – right earthing switch
ONIII-72	A = 735	A = 795
ONIII-123	A = 1335	A = 1395

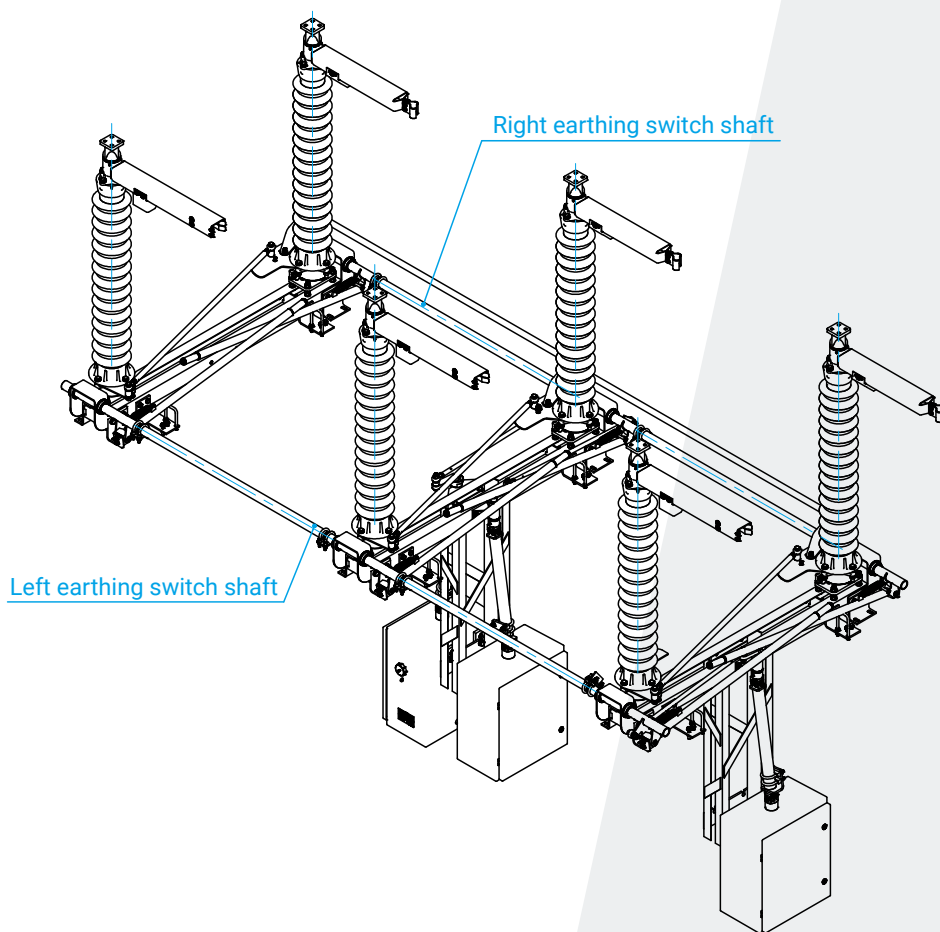

3.7. Earthing switches operating regulation

Earthing regulation consists of coupling shaft adjustment, in order to earthing blades on each pole should achieve end positions in accordance with requirements presented in the drawing below and earthing circuit closing occur simultaneously.

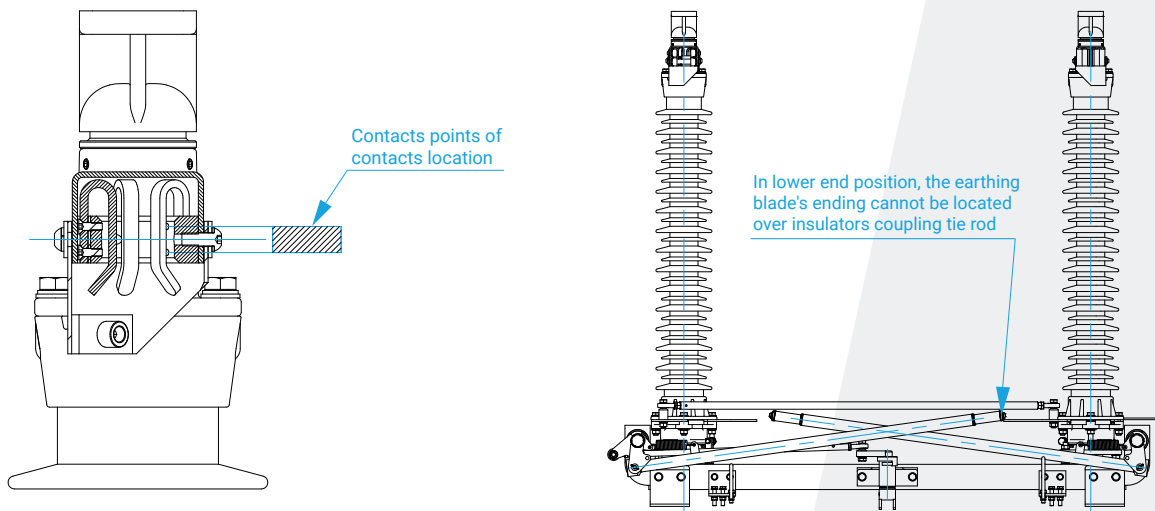

On one of earthing switches coupling rods there should be placed earthing switch blockade, in order to enable earthing work only with open disconnector. Figure blow shows the way of fitting the blockade.

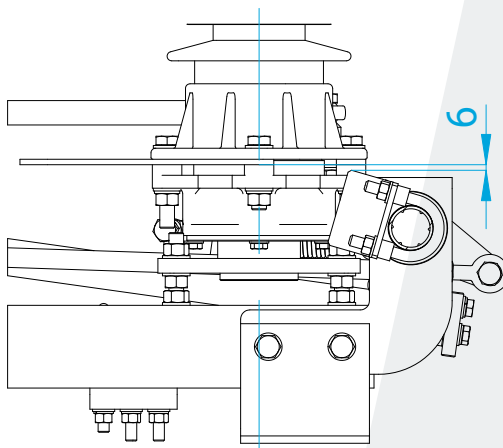

3.8. Grounding of the base frames

After regulation of the disconnecter and earthing knives the base frame should be grounded. Earthing connection points are marked on the disconnecter base. In the case of earthing the disconnecter with built-in earthing switch, the earthing line should be connected as close as possible to the cable connecting the earthing switch knife with the base. The arrangement of connections is shown in the next figure.

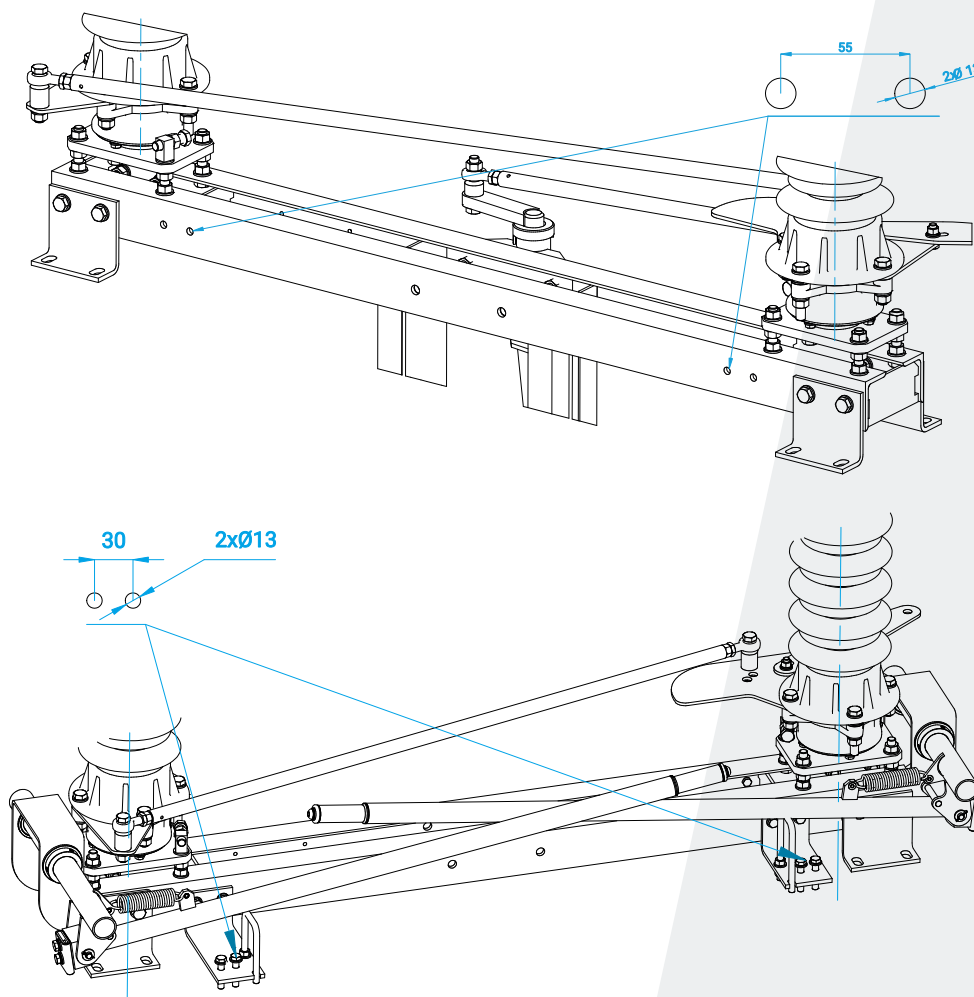

4. OPERATING MANUAL

Disconnecter's switching is achieved by using an appropriate motor or manual operating mechanisms.

4.1. Notes about connecting activities

- While disconnecter's or its earthing switch's manuevering all safety at work rules applicable in installation's location should be respected.
- Energized disconnecter can be manuevered only when capacity of intermittent current will have negligible value or any significant voltage change between any pole's contact elements would appear.

- c) The disconnecter cannot be closed until its earthing switch has been opened.
- d) Disconnector earthing switch can be manoeuvred from open to close position only:
 - If the disconnecter is in open position,
 - After ensuring that earthing switch will be working under discharging current of the bushings, rails, incoming supplies, short cables and power lines capacities, with current and voltage parameters specified in technical data.

5. INSPECTIONS AND MAINTENANCE

5.1. Visual inspections

It is recommended to carry out visual inspections in accordance with rules being in force in switchgear or after each failure or short circuit. Check in particular:

- a) condition of current path's central contacts,
- b) condition of earthing switch's contacts.

5.2. Periodical check-ups

In order to ensure continuous and failure-free operation of disconnectors, it is necessary to perform periodic check-ups. While the internal regulations in force in the distribution centre do not oblige to more frequent maintenance, inspections are required in accordance with the following schedule:

- Periodic inspection- after 5 years of operation or after 1000 operation cycles;
- General inspection of earthing switch's contacts.

During inspection and maintenance, the applicable regulations for the operation of energy devices and the requirements determining the safety work of the inspectors must be obeyed.

The scope of activities to be performed during each maintenance is as follows:

- a) Periodical inspection:
 - Check condition of current paths central contacts;
 - Check condition of earthing switch contacts;
 - Check the correctness of taking the end positions;
 - Check the condition of mechanisms and bearings
 - Check tightness of screw connections and fasteners;
 - Clean the outer surfaces of insulators;
 - Check the condition of protective coating and parts protecting against corrosion;
 - Lubricate the current path contacts and the earthing switch contacts (not required for disconnectors equipped with graphite AgC contacts) ¹⁾;
 - Perform thermal inspection of the disconnecter at rated current ²⁾;

b) General inspection:

- Perform the complete set of activities disrobed at 'Periodic inspection';
- Clean all moving parts;
- Measure the voltage drop of the disconnecter main circuits at current $I=100A$ DC ³⁾;
- Check dimensional compliance of the disconnecter with the dimensional drawing, in particular insulation gaps and spaces between live parts;
- Check the condition of anti-interference screens (if installed);
- Check technical condition of insulators ⁴⁾;
- Check the operation and condition of arcing contacts (if installed) ⁵⁾;
- Check earthing of the disconnecter bases.

¹⁾ When assessing condition of the disconnecter contacts, check if the silver coating surfaces have not been damaged permanently.. If necessary, replace damaged contacts with new ones.

²⁾ In case of thermal tests, the permissible temperature values are given in Table 14 of the PN-EN 62271-1: 2018-02 standard should be adopted as a criterion for assessing the correct operation of the disconnecter.

³⁾ In case of measuring the voltage drop of the main circuit of a disconnecter not connected to the busbar system, the acceptable values indicated in the factory test report of the finished product should be taken as the criterion for assessing the correct operation of the disconnecter. In the case the disconnecter is connected to the busbar system, the voltage drop should not be exceeded $250 \mu\Omega$.

⁴⁾ When assessing the condition of insulators, it is necessary to check if there are no losses or damage to the insulators, with particular emphasis on the surface of the shade. If necessary, replace damaged insulators with new ones.

⁵⁾ When assessing the condition of the arcing contacts, it is necessary to check whether there are no cavities or pits on the contact surfaces. If necessary, replace damaged contacts with new ones.

5.3. Spare parts and recommended service materials

The use of high quality components and exploitation experience indicate long liveness of disconnectors (about 40 years). If the disconnecter is damaged due to improper assembly or operation, it is possible for the manufacturer to repair it for a fee. Disconnecter type ONIII does not possess parts, which should be replaced during normal operation in service life.

For disconnectors maintenance, materials listed below have to be used:

- a) MOBILGREASE 28 used for lubrication of electric contacts (earthings, contacts of HV switches),
- b) LUBRICANT for bearings, for example LT4 or similar, used for lubricating ball joints.

6. UTILIZATION

The ONIII disconnectors are made of materials that are recyclable.

The main materials from which the disconnectors are built are:

- steel (hot-dip galvanized);
- aluminum;
- copper.

The disconnectors do not contain any dangerous substances. In accordance with applicable regulations, it is possible to return a worn out, complete disconnector to the manufacturer.

**Zakład Wytwórczy
Aparatów Elektrycznych Sp. z o.o.**

Gdańska 60, 84-300 Lębork
POLAND

zwae@zwae.com.pl
tel.: +48 59 863 36 15

www.zwae.com.pl

Address of correspondence:

Kębłowo Nowowiejskie, ul. Łąkowa 2
84-351 Nowa Wieś Lęborska
POLAND