

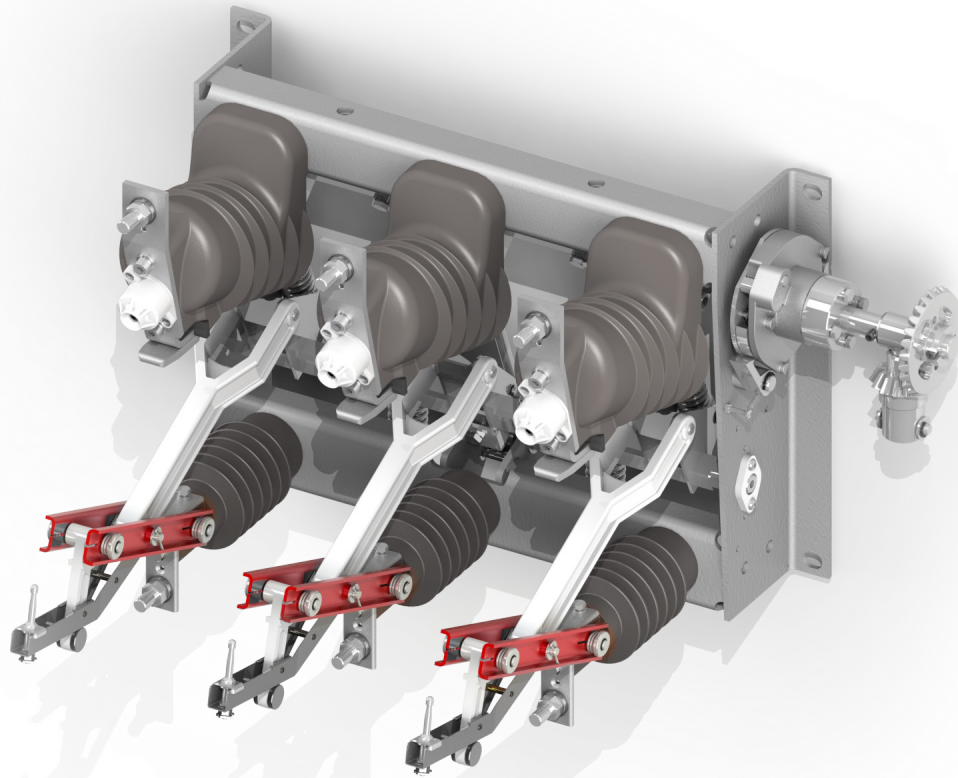

Zakład Wytwórczy Aparatów Elektrycznych Sp. z o.o.
INSTALLATION AND SERVICE MANUAL



OM/OMB

Indoor switch disconnecter

Manual no DTR.03.01.07.EN

.....○ **WARNING!**

During the operation of electrical equipment, certain parts of these devices are normally under dangerous voltage, and mechanical parts, also remotely controlled, can move quickly.

Failure to follow the warning instructions can result in serious personal injury or material damage.

Only suitably qualified personnel can work on or near the device. These personnel must know exactly all safety rules and maintenance rules in accordance with these instructions.

The trouble-free and safe operation of this device requires proper transport, proper storage, construction and assembly as well as careful service and maintenance.

Table of contents

1. Transport and storage	4
1.1 Unpacking and inspection	4
1.2. Transportation and storage.....	5
2. Description	5
2.1 Application	5
2.2 Construction and principle of operation.....	5
2.3 Environmental conditions during exploitation.....	8
3. Accessories, additional equipment.	9
4. Installation and adjustment.	11
4.1 Preparing of the supporting structure and assembly of the switch disconnecter	11
4.2 Connecting the inlet and grounding wiries	12
4.3 Assembling of the manual operating mechanism and its coupling with the switch disconnecter.....	13
4.4 Assembling of the manual operating mechanism and its coupling with the earthing switch	13
4.5 The way of regulating the switching moment of the switch disconnecter.....	14
5. Exploitation.	17
5.1 Periodic inspactions.....	17
5.2 Permitted repairs carried out by the user.....	17
6. Conservation	18
6.1 Periodical tests	19
7. Fuses selection	19
8. Utilization	20
9. Parameters of the earthing switch	20
10. Parameters of the switch disconnecter	21

1. Transport and storage

1.1 Unpacking and inspection

Immediately after receiving the apparatus, check the delivery compliance with the shipping specification. Then check whether the camera has not been mechanically damaged during transport and compliance of the data on the nameplate with the order. Upon receipt of delivery, the stretch film must be removed to ensure adequate ventilation to counteract the formation corrosion.

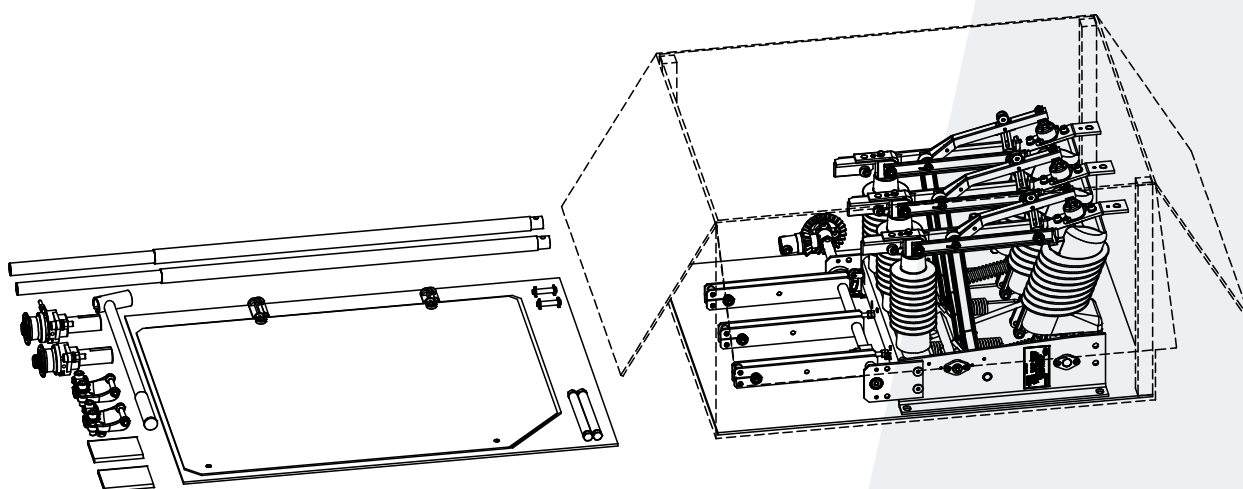

Drawing 1. Unpacking the switch disconnecter and checking completeness.

Excessive shocks should be avoided when transporting the switch. The disconnectors are delivered to the recipient in a carton, completely assembled. To reduce dimensions and ensure transport safety, the current paths [21] are in the closed position. Switching springs [23], insulation panels [6] are dismantled. NR-1 manual drives, drive links, fuse links, mounting plates and adapters are supplied separately. The replaced elements should be installed by the installation contractor during the installation of the disconnecter.

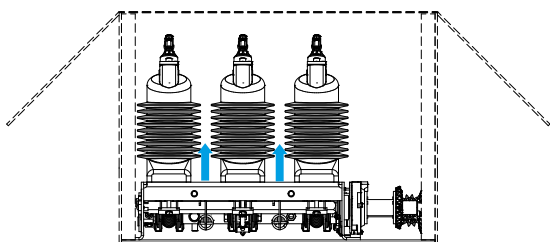

Open the packaging from above. Tear off the security elements. Pull out the disconnecter by grasping the base. Lifting or earthing knives are not allowed

Drawing 2. Pulling the switch disconnecter out of the package.

1.2. Transportation and storage

To the place of storage and installation, switch disconnectors can be transported by any means of transport, provided that they are protected against moisture. During transport, the disconnectors should be protected against moving and colliding with each other or parts of the vehicle. It is not allowed to set the disconnectors one on the other directly. It may damage the disconnector. The disconnector should be moved in a double unit or by crane.

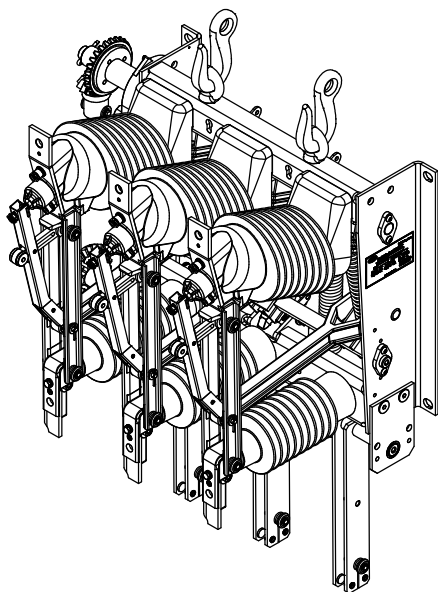

Drawing 3. The way of moving the switch disconnector by crane.

2. Description

2.1 Application

OM type OM switch disconnectors and OMB type fuse disconnectors are designed for use in indoor switching devices for a voltage from 7.2 to 24 kV. They are intended for switching on and off currents not exceeding their rated continuous current. Fuse switch disconnectors with OMB fuses, thanks to cooperation with fuse links, additionally have the ability to switch off and simultaneously limit short-circuit currents. The fuse links of such manufacturers as: ETI-POLAM, SIBA, EFEN, ABB are intended for cooperation with OMB fuses.

In the open state, the disconnectors create a safe isolation gap in the air, thus meeting the relevant requirements of standards for disconnectors.

2.2 Construction and principle of operation

OM / OMB type disconnectors are three-pole switches with a secant movement of the cutter knives. The arc extinguishing takes place in the compressed air stream automatically when opening the device.

The base of the disconnector is a welded steel frame [1]. In its sides, the main shaft [2] and the drive shaft [3] are mounted. On the transverse shelves there are resin insulators [4] and [5] supporting the main and auxiliary current paths.

The disconnectors can be equipped with auxiliary switches ŁK 3NO + 3NC [42] attached to the base of the apparatus from the opposite side of the drive at the main shaft [2], and electromagnetic release [15] located on the base under the lock of the disconnector. Cameras with reduced pole spacing (160mm for rated voltage 24kV and 125mm for rated voltage 12kV) are equipped with insulating barriers [6] between poles. Each disconnector is equipped with at least one earth clamp located on the transverse base plate, and the fuse disconnector in addition on the shelf in the fuse base.

The earthing switch connected to the fuse switch or fuse base is made in the form of steel knives [16] mounted on the shaft [17] and terminated with contact rivets [18]. It is equipped with a lock that prevents closing the disconnector with the earthing switch closed and closing the earthing switch with the disconnector closed.

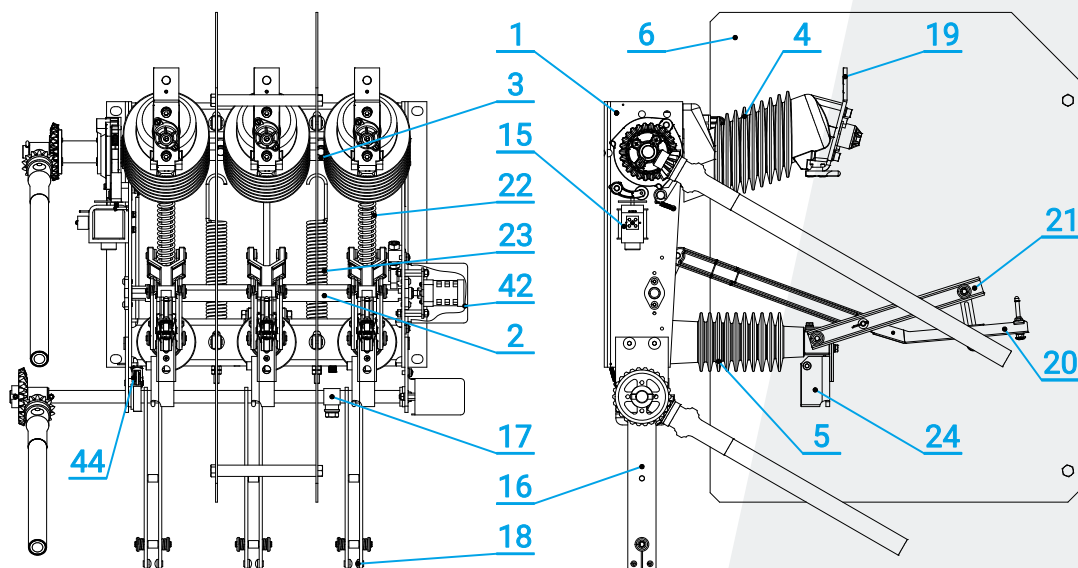

Drawing 4. Switch disconnector type OM with earthing switch

- | | | |
|----------------------------|----------------------|--------------------------|
| 1. Base frame | 15. Tripping coil | 21. Current path |
| 2. Main shaft | 16. Earthing knife | 22. Closing spring (ON) |
| 3. Driving shaft | 17. Main shaft of ES | 23. Opening spring (OFF) |
| 4. Extinguishing insulator | 18. Contact rit | 24. Earthing contact |
| 5. Supporting insulator | 19. Contact | 42. Auxiliary contact |
| 6. Insulating plate | 20. Arching contact | 44. Triggering shaft |

Fuse disconnectors have independently mounted fuse base [7], are equipped with jaws [9] placed on resin support insulators [10]. This allows you to install any length of fuse with a fitting diameter of 45 mm. Switching off the disconnector follows automatically as a result of the fuse of the fuse insert. The switch [43] used to release the fuse switch via fuses is supplied as standard with a length of 342 mm for a fuse link with a length of 442 mm and 192 for a plug 292.

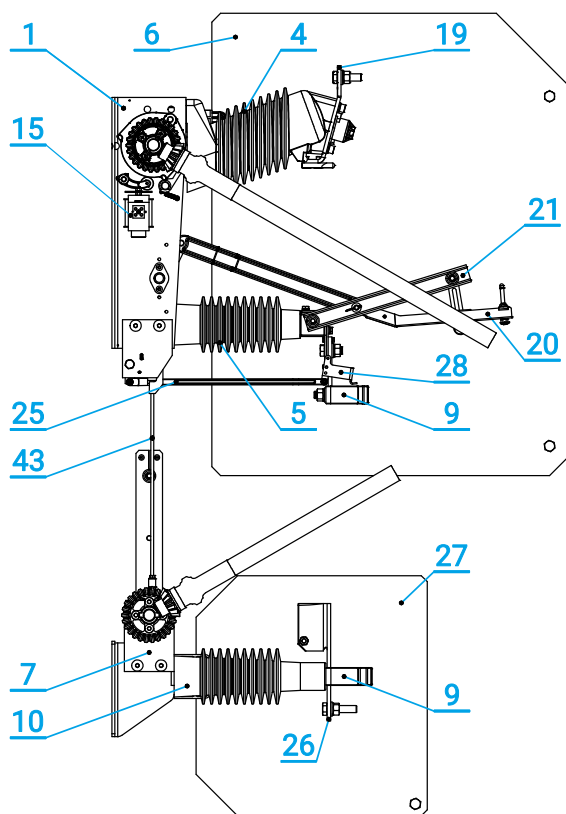

- 1. Base frame
- 4. Extinguishing insulator
- 5. Supporting insulator
- 6. Insulating plate
- 7. Fuse base
- 9. Clamps
- 10. Supporting insulator
- 15. Tripping coil
- 19. Contact
- 20. Arching contact
- 21. Current path
- 25. Triggering links
- 26. Contact
- 27. Insulating plate
- 28. Triggering lever
- 43. Linking shaft

Drawing 5. Fuse switch disconnector with earthing switch type UDM

Manual operating mechanism NR-1/01 adapted for installation above drive NR-1/02, is equipped with a hand lever [12]. The operating mechanism NR-1/02 is equipped with a mechanical lock [14] installed between the drives.

- 11. Driving rod
- 12. Manual lever
- 13. Joining clamp
- 14. Mechanical blockade
- 29. Clamp for rod
- 30. Insulated rod

Drawing 6. Manual operating mechanisms NR-1/01 and NR-1/02

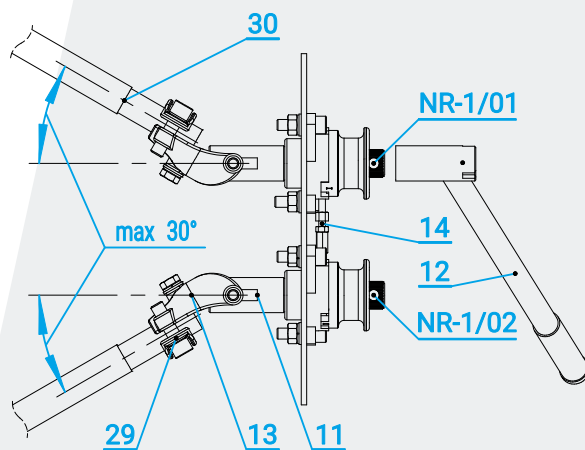

Fast earthing switch connected to the switch disconnecter also made in the form of steel knives terminated with contact rivets, mounted on the shaft. In addition, a spring system [48] and a clutch system [46], [47] are used.

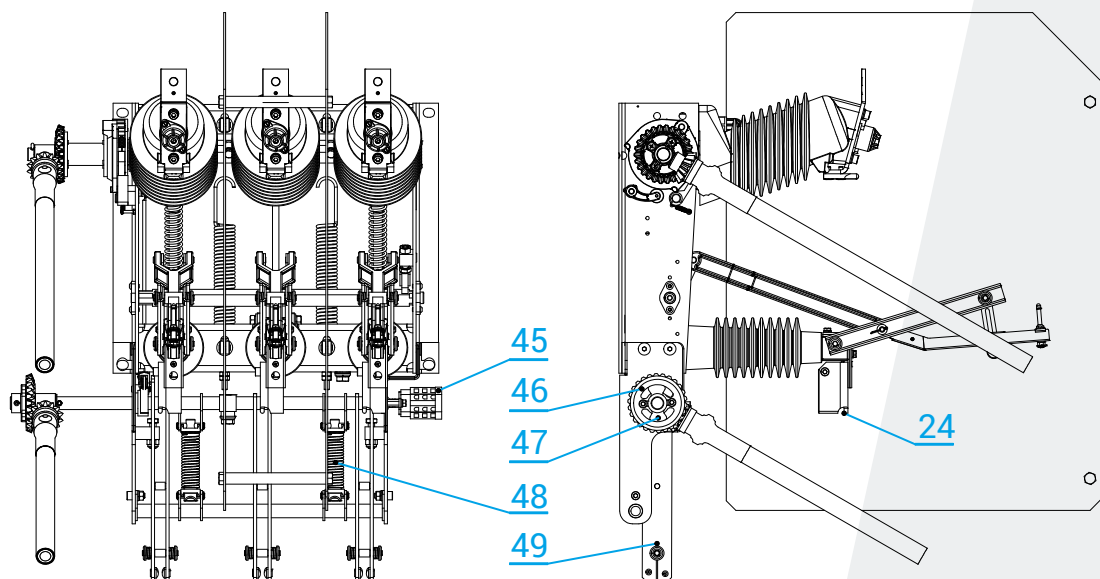

Drawing 7. Switch disconnecter OM with fast earthing switch type UDS

- 11. Driving rod
- 12. Manual lever
- 13. Joining clamp
- 14. Mechanical blockade
- 29. Clamp for rod
- 30. Insulated rod

2.3 Environmental conditions during exploitation

OM / OMB switch disconnecters are designed for installation in indoor switchgear, in normal operating conditions in accordance with PN-EN 62271-1 2.1 with the extension of the scope of use in the scope of:

- permissible ambient temperature within limits: -45°C to +40°C

The working environment must be free from dust, flammable gases, steam or salt, corrosive substances.

3. Accessories, additional equipment

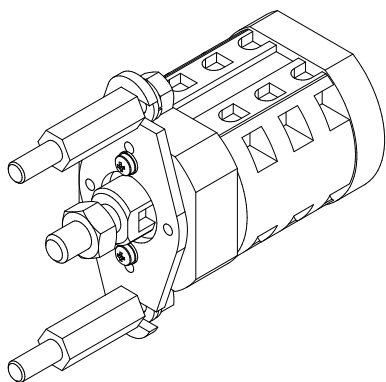

Drawing 8. Auxiliary contact switch

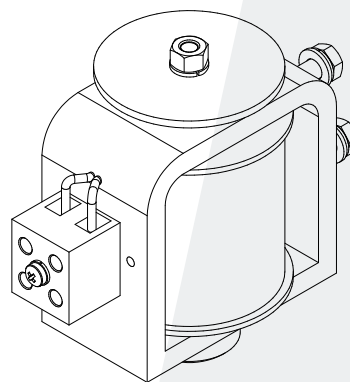

Drawing 9. Tripping coil NW-4

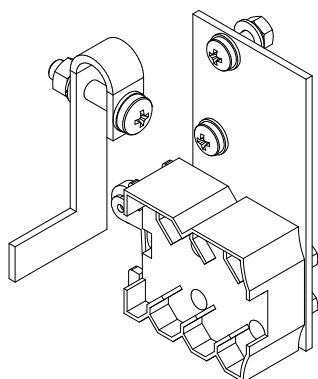

Drawing 10. Fuse overburnt indicator

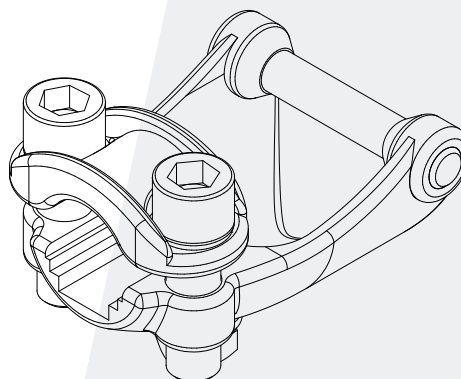

Drawing 11. Joining clamp

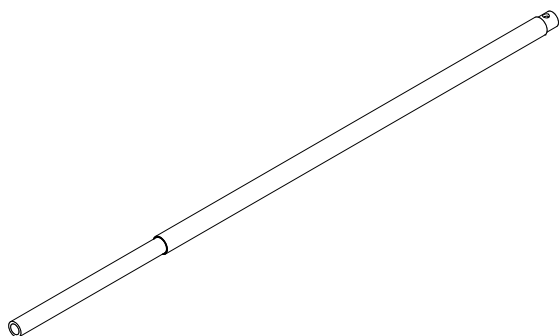

Drawing 12. Insulated coupling rod

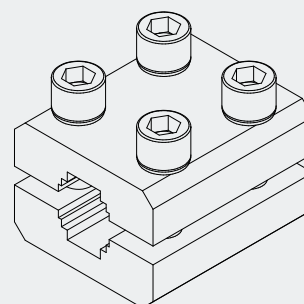

Drawing 13. Clamp for coupling rods

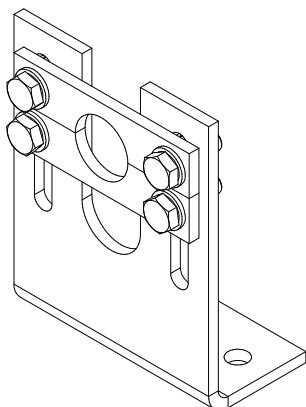

Drawing 14. Supporting bracket for rods

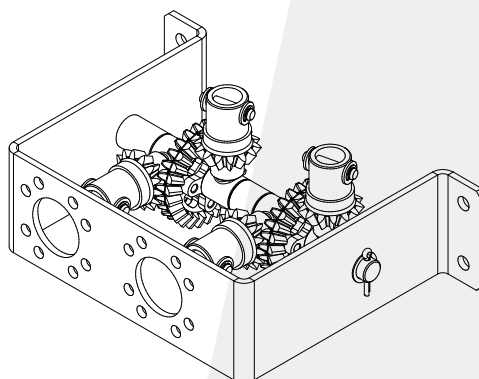

Drawing 15. Angle gear

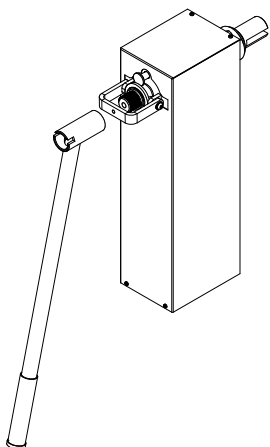

Drawing 16. Motor operating mechanism NSW30

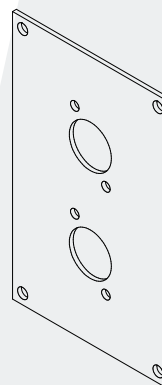

Drawing 17. Assembling plate for operating mechanisms

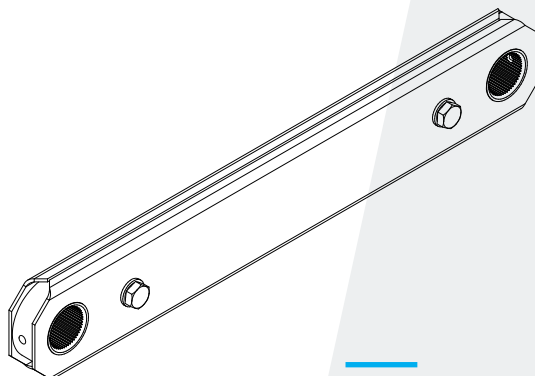

Drawing 18. Mechanical interlock between switch disconnector and earthing switch

4. Installation and adjustment

Persons performing switching activities should have sound professional qualifications and experience in servicing high-voltage equipment. When adjusting the disconnecter or its earthing switch (if installed), you must observe the safety regulations in force at the place of installation and the following conditions:

- the disconnecter can be closed only when its earthing switch is open,
- The earthing switch can be closed only when the disconnecter is open and the earthed circuit is disconnected from the voltage,
- switching on the fuse switch with fuses after automatic switch-off is possible only after arming the device, ie. Withdrawing the drive to the off-state position. Also replace blown or damaged fuse links. It is recommended to replace the fuse inserts in all poles also in the case of burning only one insert.

Before making a change (closing or opening) of the disconnecter or its earthing switch, make sure that the switching is permissible, taking into account the arrangement conditions of the switchgear.

4.1 Preparing of the supporting structure and assembly of the switch disconnecter

The design of the supporting structure should take into account the maintenance of appropriate ground insulation distances, and the construction itself should have adequate stiffness.

After removing from the cardboard, put the disconnecter on a stable surface, cut the spring protecting band. Strongly pull the two extreme current tracks. This will open the switch and block the main shaft.

Then unscrew the eyebolt nuts, turn the disconnecter and mount the switch springs, moving the coupling hook through the eye of the screw. Tighten the springs by tightening the nuts to about half the thread. Secure against unscrewing by the counter nut.

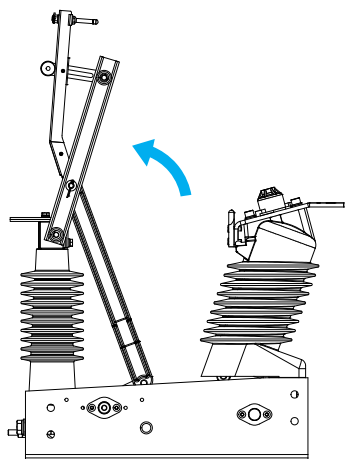

Drawing 19. Opening of the switch

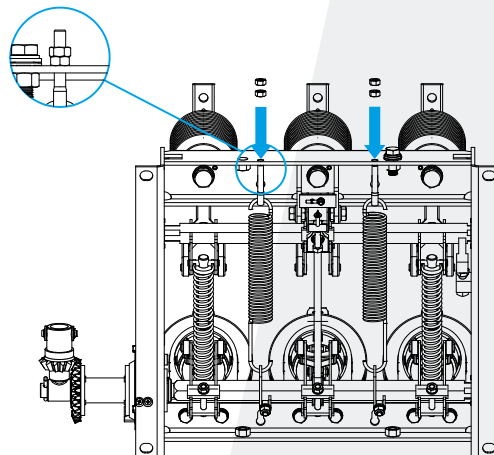

Drawing 20. Stringing ON/OFF springs

Fasten the base of the switch-disconnector in three places (with three M12 bolts), and then place possible washers under the base for leveling the plane of the supporting structure. The contact points of the support structure with the disconnector base should lie in one plane. After completing the assembly of the disconnector, assemble and fit the insulation barriers.

..... **Warning!**

It is not allowed to close the disconnector by pressing on the current paths. The camera may be maneuvered only by operating the lever.

4.2 Connecting the inlet and grounding wiries

Before screwing the rails, disconnect the disconnector connections from any contamination by a method that does not damage the silver coatings. The contact surfaces of the connections and rails should be lubricated with a thin layer of acid-free Vaseline or other electric connection grease. Tighten the screws carefully to 70 Nm using two wrenches. When connecting stranding from the rod use the overlays. When tightening the screws, be careful not to disturb the settings of the disconnector or earthing switch itself. Slight adjustment of the connection may cause the malfunction of the apparatus.

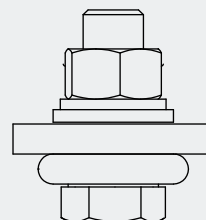
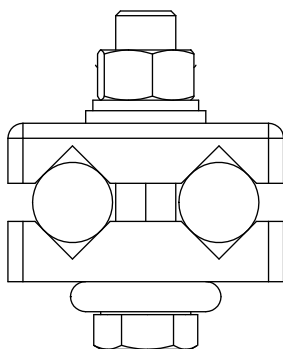

Drawing 21. The way of connecting the railing with the rod using the pads and rail

Connect the earthing conductor to the base by tightening with a torque of 70Nm the screw placed in the earthing terminal located on the upper or lower shelf of the switch disconnector base. The connection should be protected against corrosion with acid-free Vaseline.

4.3 Assembling of the manual operating mechanism and its coupling with the switch disconnector

The manual drive type NR-1 should be mounted on the front wall of the switchgear in position „0” by means of two M10 allen screws. The axis of its shaft should lie (visually assessing) in the plane of the axis of the smaller gear wheel. Make sure that the angle between the tubular shaft and the drive axis does not exceed 30°. Before connecting the drive to the disconnector, cut the tension rod [30] so that on one side the pipe with the hole can be placed in the smaller toothed wheel [34] and on the other in the clamp [29]. After placing the insulated end in a small toothed wheel and securing with a bolt [33], put the insulating sheath of the bolt [32] from the heat shrink tube supplied with the NR-1 drive. When screwing the clamp clamp, select the play on the toothed wheel and the lock mechanism by turning the shaft to the right side until the clutch plate with the pawl gets clogged.

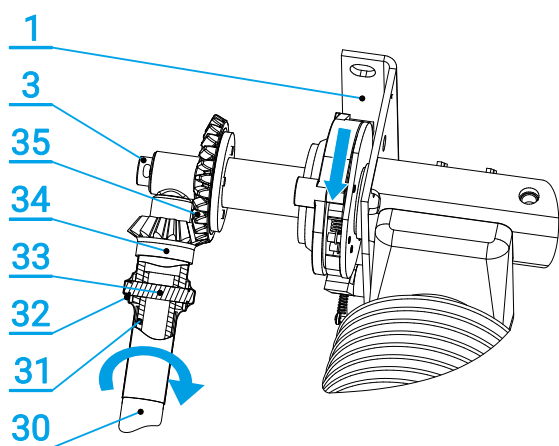

- 1. Base frame
- 3. Driving shaft
- 30. Insulation of the coupling rod
- 31. Coupling rod
- 32. Pin insulation cover
- 33. Safety pin
- 34. Small gear
- 35. Large gear

Drawing 22. The way of connection of the coupling rod of the drive with the switch disconnector.

4.4 Assembling of the manual operating mechanism and its coupling with the earthing switch

When assembling the earthing switch, the drive must ensure proper opening and closing conditions of the earthing switch. To do this, close the earthing switch and set the manual drive in the „I” position. Tighten the clamping clamping screws [29]. In addition, the lock length must be adjusted to maintain the correct switching cycle. With correctly made adjustment, the blocking eye [14] can not be activated by the earthing switch when the disconnector drive is closed and vice versa. In the case of the open state of both devices, it should be possible to operate with any drive. Activation of the drive should be initiated by pulling the sleeve (approx. 5mm) in the body, in order to unlock it. After this operation, the lever should be moved by 180°.

In case of coupling the drive with the high-speed earthing switch UDS, the earthing switches should be in the open position and the drive should be in the „0” position. Position the clutch discs [47] halfway between the disc drive bolts [46] and tighten the clamping bolts. Check interaction with the drive. If necessary, turn the shaft in the clamp slightly to obtain the correct operating conditions.

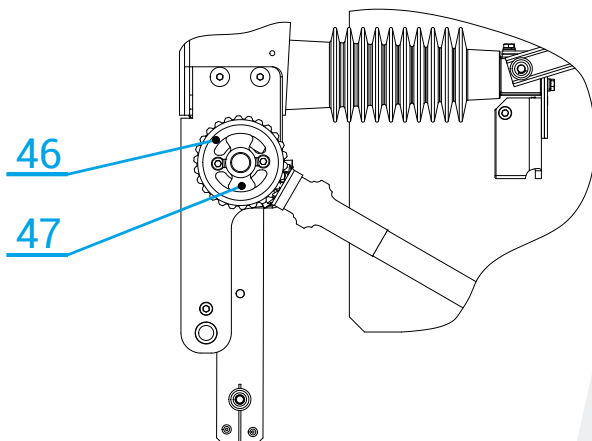

Drawing 23. Location of the fast earthing clutch UDS during coupling with the drive in position I

4.5 The way of regulating the switching moment of the switch disconnecter

The disconnecter is delivered assembled and adjusted. In the case of tightening the switch to uneven ground or after transporting the station, it may happen that, despite having chosen the slack on the drive, reaching the „I” position on the drive and snapping the hook on the drive shaft was not activated.

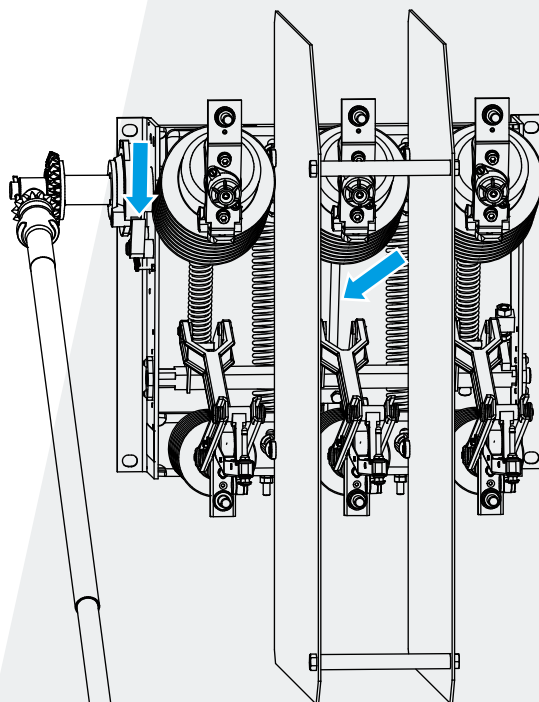

Drawing 24. Disconnecter in a condition requiring adjustment

To solve this problem, turn the disconnecter drive back to position „0”. The release of the spring mechanism will be audible. Visually check that the springs are not stretched. Then remove the insulating barriers to gain access to the trigger rod.

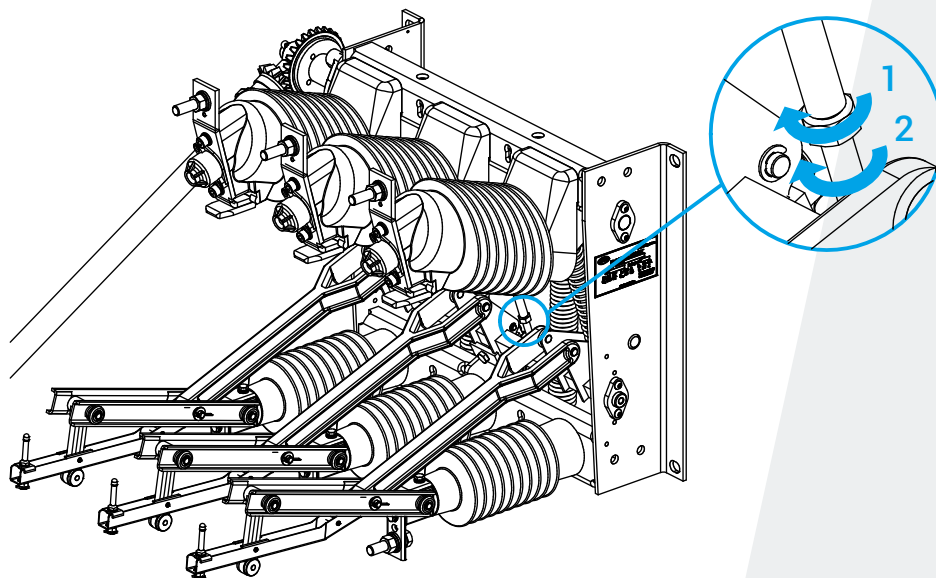

Drawing 25. Adjusting the length of the tie rod

Loosen the counter nut of the tie rod by turning clockwise. Extend the trigger cable by turning about half a turn clockwise with the threaded pin. Try closing the disconnecter by turning the drive. The hook should jump on the pawl simultaneously with the closing of the disconnecter. If not, open the switch disconnecter with the drive and adjust the length of the tie rod until the desired effect is obtained.

Warning!

Never approach the disconnecter when the springs are tight. Unintended operation can cause sudden opening. Operations can only be performed in the open state. Failure to comply with this rule will result in serious bodily injury.

After adjusting, tighten the counter nut of the release cable counterclockwise. Check the correct opening, closing and triggering of the disconnecter with earthing switch. In case of further problems, please contact the ZWAE website.

.....○ **WARNING !**

Before switching on the live disconnectors, the user should make sure that the assembly has been made correctly and check that the status of disconnectors and drives as well as the method and place of installation correspond to the conditions of safe operation. In particular, it is necessary to inspect the apparatus paying attention to the condition of insulators, contacts and correct tightening of screw connections.

This requirement is particularly important when transporting distribution stations with disconnectors to the place of operation.

Failure to perform inspection activities can lead to serious breakdowns of distribution stations. In case of difficulties, the regulator should be ordered by the manufacturer.

5. EXPLOITATION

During the switching operations, we recommend to each time inspect the external disconnecter, paying attention to the correct achievement of final states by the apparatus, as well as the condition of soiling insulators, insulation cables and contact states and drive mechanisms.

If there are any significant faults that could damage the disconnecter or endanger the safety of operation, the device should be immediately disconnected from the voltage and the faults should be rectified.

5.1 Periodic inspections

It is recommended that the breaker inspections be carried out:

- during periodic inspections of the interior switchgear,
- after switching on short circuit.

The switching capacity of the disconnecter is jeopardized if the melting of the thermal contacts causes a clear deformation of their shape and the burning out of the blow nozzles increases their outlet opening. The operating contacts and blow-off nozzles indicating this state of wear must be replaced with new ones

During inspections, please check in particular:

- condition of insulators and insulation rods, attention should be paid to the contamination of their surfaces and possible mechanical damage (scratches, cracks, etc.);
- the condition of main contacts, paying attention to possible damage (marks of fouling, silver coating defects) in places of mutual contact;
- the degree of wear of the thermal contacts and blow-off nozzles;
- condition of cushioning washers on insulators at fixed contacts of the disconnecter;
- condition of the earthing switch and its contacts as well as earthing and grounding terminals.

5.2 Permitted repairs carried out by the user

Repair of disconnectors made if necessary by the user should not go beyond the replacement of parts specified in the spare parts list and the adjustment of contacts and mechanisms conditioning the correct operation of the apparatus. Spare parts subject to wear during operation are delivered with an order.

More complicated repairs requiring dismantling of the disconnecter can only be carried out by the manufacturer. The manufacturer is not responsible for the work of disconnectors overhauled by the user, if the repair included the performance of activities without consulting the manufacturer.

The switch disconnecter elements which might be replaced

Item	Name of the element	Amount
1.	Blow nozzle [36]	3
2.	Arcing roll [37]	6
3.	Spring [38]	6
4.	Damper [39]	3
5.	Fixed contact [40]	3
6.	Current path [21]	6
7.	Arcing contact [41]	3

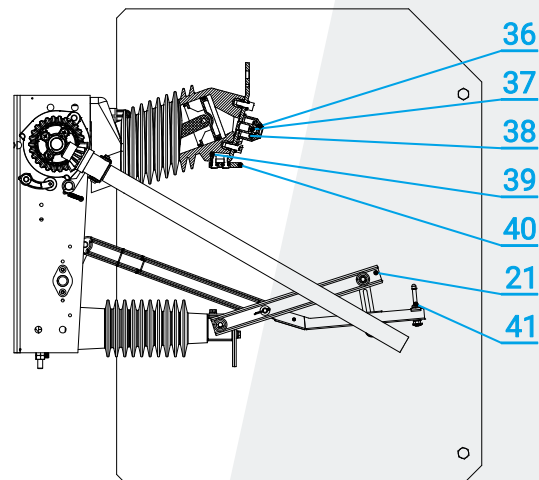

Drawing 26. The switch disconnecter elements which might be replaced

In the event of replacing spare parts of the fire extinguishing system, check the correctness of closing the disconnecter contacts. For this purpose, with the open apparatus release the main shaft lock by moving the trigger cable manually towards the shaft and operating the handwheel lever to the right at „0”. Lead the main knives [21] with a fixed contact [40]. The position of the track in relation to the contact should be coaxial and the arcing contacts should go exactly to the center of the blow nozzle [36]. When replacing the blow nozzle, seal the adjacent nozzle part with a flat contact surface with a silicone sealant.

6. Conservation

Maintenance of the disconnecter is recommended to be carried out after each inspection. The scope of maintenance includes:

cleaning the insulators and tie rods with dry cleaning;

- lubrication of main contacts with MobilGrease 28
- replacement of the thermal contacts and blow-off nozzles, if the degree of wear is excessive;
- replacement of cushioning pads in case of noticed cracks;
- tightening of any loose screw connections;
- replenishment of damaged protective coatings ;,
- cleaning and lubricating the earthing switch contacts.

6.1 Periodical tests

After the inspection, maintenance and possible repair of the disconnector, it is necessary to check the correctness of the mechanical operation and, if necessary, adjust the mechanisms. It is also advisable, especially in the case of doubts regarding the assessment of surface damage of the main contacts in places of mutual contact, additionally check the resistance of the main current path. This is especially important for disconnectors that conduct continuous currents with values close to their rated current. Measured resistances in each track should not exceed $60\mu\Omega$.

Measurements of the current resistance of the disconnector and isolation should be carried out in accordance with the regulations in force in the power industry.

7. Fuses selection

For use with OMB switch disconnectors, it is recommended to use EFEN type HH-2 fuse links. These fuses in accordance with the PN-EN 62271-105 standard are reference inserts. The selection of inserts for the protection of distribution transformers together with the characteristic assumptions regarding operating conditions and the selection method are presented in the table below.

Nominal voltage of the transformer [kV]	Nominal power of the transformer [kVA]															Nominal voltage of the fuse [kV]	
	50	75	100	125	160	200	250	315	400	500	630	800	1000	1250	1600		
Nominal current of the fuse type HH-2 (EFEN)																	
3	16	25	31,5	40	50	63	80	100	-	-	-	-	-	-	-	-	3/7,2
5	-	16	20	25	31,5	40	50	63	80	100	-	-	-	-	-	-	3/7,2
6	10	16	16	20	25	31,5	40	50	63	80	100	-	-	-	-	-	3/7,2
10	6,3	10	16	16	20	25	31,5	40	50	63	63	80	100	-	-	-	6/12
12	4	6,3	10	16	20	20	25	31,5	40	40	50	63	80	100	-	-	6/12
15	4	6,3	10	10	16	20	20	25	31,5	40	40	50	63	80	100	-	10/24
20	4	4	6,3	6,3	10	10	16	20	20	25	31,5	40	50	63	80	-	10/24

The rated current data for the individual inserts presented in the table depend on the given operating voltages and transformer data.

The above values were obtained assuming the following parameters:

- maximum long-term load - 150% - standard working conditions of inserts
- inrush current - $12 \times I_n$ for 100ms - own disconnector time - 67ms
- short-circuit impedance - 5% - maximum transient current 1000A.

For other work parameters, the selection of the inserts must be made individually.

8. Utilization

OM / OMB switch disconnectors are made of materials that are recyclable.

The main materials from which the disconnectors are built are:

- steel (painted, galvanized);
- copper (painted, silver-plated);
- plastics (epoxy mixture, polyamide).

The disconnectors do not contain any dangerous substances. In accordance with applicable regulations, it is possible to return an exhausted, complete disconnector to the manufacturer.

9. Parameters of the earthing switch

Item	Parametr	Value			
		UD/UG-12	UD/UG-24	UDS/UGS-12	UDS/UGS-24
1.	Class of the earthing switch	E0	E0	E1	E1
2.	Short-circuit withstand current, 1-sec.	20kA	20kA	20kA	20kA
3.	PRated short-circuit making current	-	-	40kA	40kA

10. Parameters of the switch disconnecter

L.p.	Parameter	Value	
		OM/OMB-12	OM/OMB-24
1.	Rated operating voltage	12 [kV]	24 [kV]
2.	Rated frequency	50 [Hz]	50 [Hz]
3.	Rated continuous current	630 [A]	630 [A]
4.	Rated transitive current	700 [A]	1000 [A]
5.	Switching capabilities: - low inductance circuit - ring network circuit - cable and overhead line loading	630 [A] 630 [A] 50 [A]	630 [A] 630 [A] 25 [A]
6.	Maximum fuse cartridge size	100 [A] ¹⁾	63 [A]
7.	Rated short-circuit making current	50 [kA]	40 [kA]
8.	Peak withstand current	50 [kA]	50 [kA]
9.	Short-circuit withstand current, 1-sec.	20 [kA]	20 [kA]
10.	Test voltage (50Hz) for insulation: - earth and pole to pole insulation - terminal to terminal	28 [kV] 32 [kV]	50 [kV] 60 [kV]
11.	Surge test volatage: - earth and pole to pole insulation - terminal to terminal	75 [kV] 85 [kV]	125 [kV] 145 [kV]
12.	Mechanical endurance	2000 cycles	2000 cycles

¹⁾ It is allowed to use fuses 120A type HH produced by SIBA

Zakład Wytwórczy Aparatów Elektrycznych Sp. z o.o.

Gdańska 60, 84-300 Lębork
POLAND

zwae@zwae.com.pl
tel.: +48 59 863 36 15

www.zwae.com.pl

Correspondence address:

Kębłowo Nowowiejskie, ul. Łąkowa 2
84-351 Nowa Wieś Lęborska
POLAND